



# Secondary containment: Protecting soil and groundwater

*The devil is in the details*

How often do you complete a secondary containment project only to find it needs repairing? With no spillage, all the system has to do is sit there. Sit there it does — through winter, spring, summer and fall; day and night; with heat, rain and soil settling; through mechanical work and more.

In the coatings and linings business, all emphasis is on the large surface, which is the impermeable barrier or the bulletproof shield between a spill and the soil. But in the quest for durable containment, this is not the weak link. Granted, some chemical exposures require high-performance robust linings to resist attack, but the majority of secondary containment service is benign to epoxy or urethane linings. The goal for these areas is also to achieve a leak-proof structure that remains maintenance-free for years to come. For this, we must sweat the details.

When I first started servicing waterproofing products at Carboline, I asked a veteran, “Since we are laying a membrane over the concrete, what does the caulk do?” He replied, “It fails.” And fail it does — on my windows and patio, and on the sidewalks at the grocery store. I have since learned how to maximize sealants’ service lives. Proper engineering design and specification of structural details can maximize service life for your containment system.

This article provides insight into the philosophy and design approach needed for durable containment systems. Below are some examples of good design practices for your next secondary containment project.

Start with the design of a new containment structure. Yes, we’re basically making a swimming pool. A few design details will go a long way toward keeping it watertight. Proper construction design includes the design and placement of expansion and control joints, use of water stops, and soil compaction to support tanks or trucks and reduce settling and cracking. There are tons of resources on the Web. It seems every state publishes guidelines for its agricultural industry. A good Web resource can be found at <http://datcp.wi.gov/uploads/Environment>.

Coatings and sealants require some forethought in the construction planning phase. Coatings and linings require dry concrete to avoid blistering while they cure. Plan on allotting 28 days for concrete to cure, which allows water to react and evaporate. A plastic barrier under the slab helps here as well. The long cure time may reveal shrinkage cracks but also allows expansion joints to reach a more typical dimension, reducing the demand on sealants. Vibrate forms to eliminate rock pockets and trapped

air. Everyone will appreciate no surprises when the forms are removed.

Surface preparation is required to provide an anchor for the lining to adhere and stay adhered. Abrasive blasting is common with dry abrasive, but other methods can be employed where it is not allowed. The abrasive will open hidden cracks and remove poorly adhered laitance that otherwise separates from the concrete with the lining. Of course the devil is in the details, and they are hard to describe without illustrations. Below are some common construction details shown with commentary. They should be part of your specification. Also, if you can identify their locations on containment design drawings, it is all the better for the contractor, the estimator and the inspector. Yes, you should have an inspector who maintains hold points requiring sign-off before the next step. Here are some inspection hold point examples:

- Concrete cure and water content
- Preparation of control and expansion joints
- Surface preparation
- Important construction details

If appearance or cleanability is important, a mockup will be useful as a standard for the project.

## Bidding the work

I highly recommend using experienced contractors — the company and the crew — for this lining work. An expert crew is well-choreographed, anticipates problems, has all the right tools and is familiar with the lining materials. Once you have qualified contractors, it is important they understand the scope of work clearly. A pre-bid and certainly a pre-job conference are in order. The specifications should be clear and define access hierarchy by other trades during construction or a turnaround.

## The materials

User-friendly systems with acceptable chemical resistance are preferred over highly chemical-resistant linings that are not so friendly. After all, the rule in secondary containment is the spill should be cleaned up within a few days. In chemical process areas with persistent leaks, you may favor more resistant linings. Sealants and membranes must also be practical for the contractor. Sealants come in many varieties, including single-package caulk type, two-component

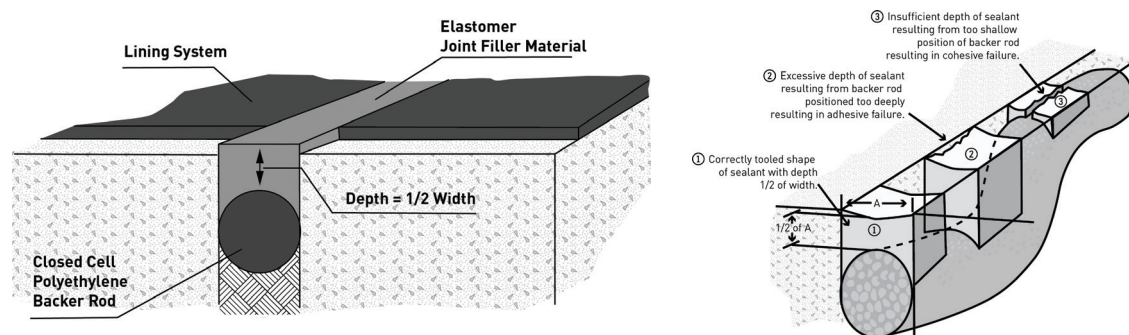

Sealing expansion joints. The backer rod is critical to establishing sealant dimensions and tooling of sealants against the joint walls. Self-leveling sealants will flow nicely into horizontal joints. Either way, the backer rod needs to be a firm fit at the right depth. A sealant that flexes readily with good adhesion will stay intact.

epoxies, urethanes, polyureas and silicones. For simple expansion joint service, i.e. foot traffic only, the sealant should have good adhesion to concrete and decent elongation. Equally important, however, is its ability to expand easily to maintain adhesion to the joint wall.

The lining is usually 100-percent solid by volume epoxy or urethane, with limited working time. Some of these offerings are more resistant to bubbling caused by concrete outgassing than others. Concrete warming as the day progresses tends to expel air and moisture, which blows bubbles in the wet lining. I recommend “chasing the sun” and applying linings after the concrete has heated up and begins to cool, thus drawing the material into the concrete. An experienced contractor can minimize bubbling with application techniques and planning.

## Attention to detail is key

Installation of durable containment systems requires attention to detail, experienced contractors and friendly materials with a dose of inspection. Products and accessories specifically designed for this application will bring the best results. Your lining supplier should provide detailed drawings to incorporate in the bid documents and recommend qualified contractors. Ask your supplier to attend the pre-bid or pre-job conference as well.

For more information, visit [www.carboline.com](http://www.carboline.com) or call (314) 644-1000. ●

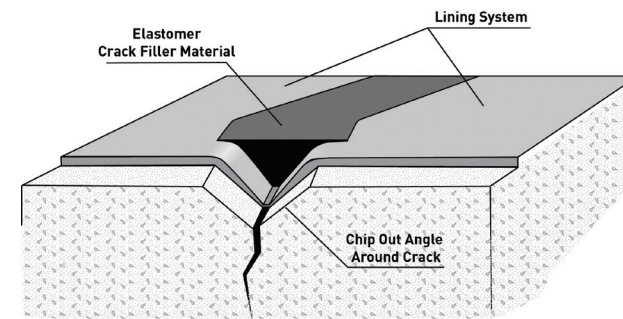

Shrinkage cracks require surface area for sealants to be durable. Routing the crack into a “V” shape enables the sealant to handle slight movement without splitting at the crack edge.

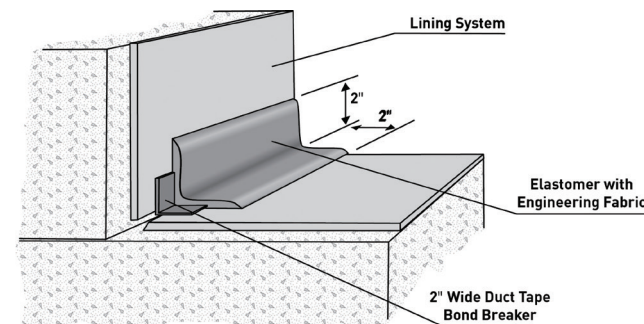

Vertical and horizontal cold joints require a bond breaker to give the elastomer freedom to move. Using an engineering fabric like needle point polypropylene adds tensile strength and, coupled with the bond breaker, absorbs movement.

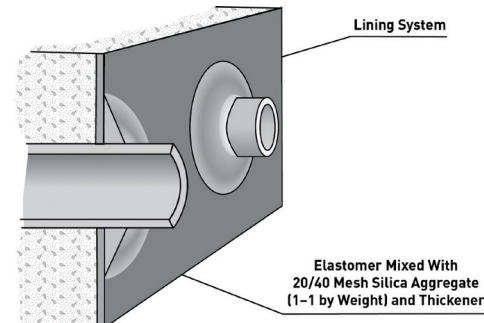

Here is an example of a simple system. Pipe penetrations must allow for differential movement between the concrete and pipe, including vibration and fluid hammer. If a lot of movement is expected, a bellows-type design incorporating a bond breaker is required.